

High Performance Computing (HPC)

High-performance computing (HPC) has traditionally used supercomputers, computer grids and more recently, utility or cloud computing to solve advanced computational problems.

Recent technology innovations such as commodity hardware based utility computing are bringing down the high upfront cost associated with computational analysis. Whether you're a multi-billion Euro corporation, fledgling start-up or budding entrepreneur you can take advantage of these developments.

Traditional HPC Benefits

- **Efficiency**
Advanced scheduling software ensures higher utilization of IT resources.
- **Productivity**
Competitive business advantage with faster time to results.
- **Throughput**
HPC permits enterprises to perform complex calculations in a short time

Cloud HPC Benefits

- **Near Zero Upfront Infrastructure Costs**
Public clouds are ready and available for HPC use.
- **Ongoing Cost Savings**
Only pay for what you use (pay-as-you-go)
- **Virtually Infinite Resources**
Massive scalability, ability to scale and use a very large number of servers within minutes
- **Elasticity**
Flexible, demand driven capacity, relinquish servers on completion of tasks, no delay in provisioning resources

The Server Labs HPC Key Features

- **Application Workload Management**
Creation of task workflows.
- **Cluster Provisioning and Node Management**
Deploy managed virtual clusters.
- **Distributed Computing**
Increase the throughput of your process by running it distributed.
- **Adaptive scheduling**
Automatic scale up or down the number or working nodes.
- **Application centric User Interface**
Users can immediately begin submitting and monitoring their jobs through a configurable web-based job submission and management interface.
- **Unified Management:**
Unified web interface for centralized management of all the described features.

The Server Labs HPC Services

HPC Cloud Framework

- Utilize public, private and hybrid clouds for HPC

HPC as a Service

- Implement public HPC cloud services

HPC Strategy

- Infrastructure readiness assessment
- Solution design and technology selection
- Technology Proofs of Concept

Design, Architecture and Implementation

- Complete architecture solutions
- Application migration and deployment
- Full scalable application development services
- Security

Managed Services

- Platform and infrastructure management and support

The Server Labs has contributed to the design and development of a HPC generic framework for the Gaia project at the European Space Agency (ESA)

Elastic HPC from clusters to clouds

The Server Labs has contributed to the design and development of a generic HPC framework for the Gaia project at the European Space Agency (ESA). The Gaia mission will have to process vast quantities of data collected in space, and this data cannot be processed with traditional architectures. The framework provides scientists with a flexible and scalable architecture to design and execute scientific algorithms in order to process the Gaia data.

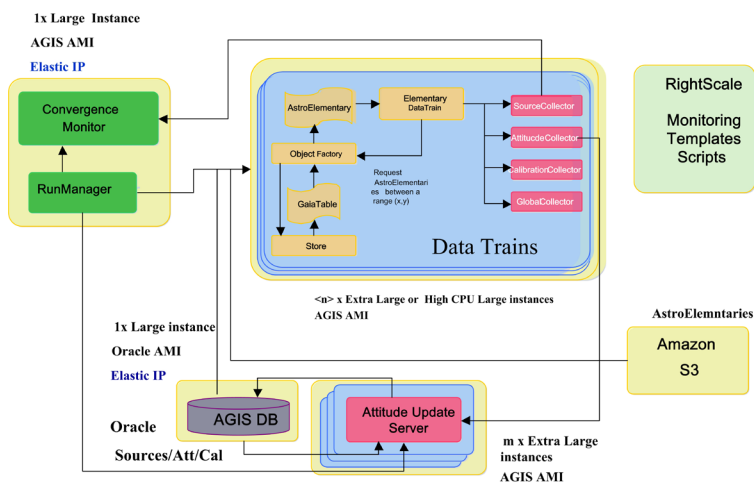

The framework was designed to be very light, scalable and robust in order to better utilize the infrastructure resources and that is its competitive advantage. The result of this work is a highly efficient architecture that keeps CPU's busy processing data and it pushes the network to the limit. The in house developed HPC framework performs much better than other HPC solutions available in the market and at a lower price.

Another key feature is that it has been developed in java, getting benefit of the latest multithreading core libraries and its portability. Write once and run anywhere it really makes sense, as we were able to deploy the HPC infrastructure in the Amazon EC2 cloud with only minimal code changes.

If it took 1 millisecond to process one image, the processing time for just one pass through the data (on a single processor) would take 30 years. The developed HPC solution is incomparably faster. The key benefit of its distributed processing capability is that it allowed us to perform the same processing in a matter of hours.

The Server Labs

The Server Labs (TSL) is a specialist IT consultancy and development company and a leading authority in Cloud Computing services. Founded in 2004, The Server Labs focuses on the design and implementation of IT architectures and advanced software engineering projects, working with the most advanced solutions and technologies and offering its clients cost-effective, scalable and high performance solutions.

TSL's customer groups are predominantly large and medium-sized corporations which share a growing need for cost effective and scalable IT solutions. TSL has offices in Spain, Germany and the UK. Most recently TSL started partnering with Amazon and RightScale to facilitate the adoption of Cloud Computing in Europe.

For more information about The Server Labs and the services we can offer you please visit our website www.theserverlabs.com.

If you would like to talk to us directly please contact us at our offices in the United Kingdom, Spain or Germany.

The Server Labs Ltd.

Aston Court
Kingsmead Business Park
Frederick Place High Wycombe, HP11 1LA, UK
Phone: (+44) 20 8133 1620

The Server Labs S.L.

C/ Pinar, 5
28006 Madrid, Spain
Phone: (+34) 91 745 68 77
Fax: (+34) 91 745 66 99

The Server Labs

Frankfurter Welle
An der Welle 4
60322 Frankfurt, Germany
Phone: (+49) (0) 69 2547 2490

info@theserverlabs.com
www.theserverlabs.com

